

SIDLEY STANDARD DIAMOND DRESSING TOOLS

SINGLE POINT



STANDARD SHANK: 7/16" x 2" Lg.
Also available in any fraction or mm size upon request.

Ordering Example: SP-AA-25 7/16" x 2"

ROTO-INDEXABLE HEAD

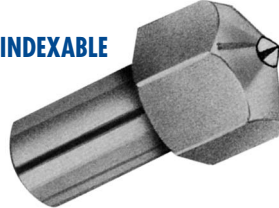

STANDARD SHANK: 7/16" x 3/4" Lg.

Ordering Example: SR-AA-25 5/8" Head

Approx. Ct. Wt.	Tool No.	Tool No.	Tool No.	Tool No.
.05	AA-05	A-05	B-05	C-05
.10	AA-10	A-10	B-10	C-10
.15	AA-15	A-15	B-15	C-15
.20	AA-20	A-20	B-20	C-20
.25	AA-25	A-25	B-25	C-25
.30	AA-30	A-30	B-30	C-30
.50	AA-50	A-50	B-50	C-50
.75	AA-75	A-75	B-75	C-75
*1.00-UP	AA-100	A-100	B-100	C-100

SIDLEY PROFILE DRESSERS

CHISEL POINT

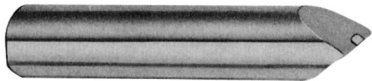

STANDARD SHANK: 7/16" x 2" Lg.

Ordering Example: CH-60° x .010 Radius 7/16" x 2"

CONE POINT

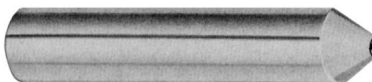

STANDARD SHANK: 3/8" x 2" Lg.

Ordering Example: CP-60° x .010 Radius 3/8" x 2"

FULL BALL RADIUS



STANDARD SHANK: 3/8" x 2" Lg.

Ordering Example: FB-.010 Radius 3/8" x 2"

DIAFORM

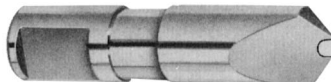

STANDARD SHANK: 3/8" x 1-3/4" Lg.

Ordering Example: DF-40° x .010 Radius 3/8" x 1-3/4"

MOORE PANTOGRAPH



Ordering Example: MO-30° x .005 Radius

HOGLUND

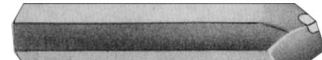

Ordering Example: HG-72° x .020 Radius

J&L

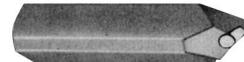

Ordering Example: J&L-1-50° x .017 Radius

STANDARD THREAD GRINDER TOOLS

JONES & LAMSON

STANDARD SHANK: 1/4" x 1" Lg.

Note: Non-Resettable

Ordering Example: JLS

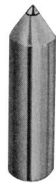

Tool No.	Type Diamond	Maximum Radius On Point
JLS	Natural Crystal	.010

EXCELLO

STANDARD SHANK: 3/8" x 1-5/8" Lg.

Ordering Example: XLO-48-4105



Excello Tool No.	Type Diamond	Maximum Radius On Point
48-4105	Natural Crystal	.010
*48-4128	Natural Crystal	.006

*Note: Quoted on request.

SIDLEY PHONO POINT TOOLS Concave and Convex Dressing

STANDARD SHANK: 1/8" x 1" Lg.

Ordering Example: PP-60° HD



Included Angle on Diamond

60°
75°
90°
60° H.D.
75° H.D.
90° H.D.

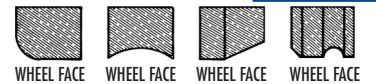

SIDLEY BLADE DRESSERS

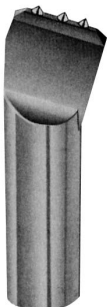

PROFILE, STEP AND RADIUS DRESSING

Manufactured to customer specifications.

Ordering Example: BTM-3-15°

CLUSTER

STRAIGHT DRESSING



STD. SHANK: 7/16" x 1"
5/8" Head

Ordering Example: SD-5

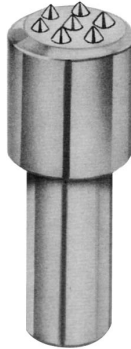

SID-BLAST

STRAIGHT DRESSING

For Large Grinding Wheels
20" x 6" and Larger



STD. SHANK: 7/16" x 1" Lg.

Ordering Example: SB-7/16" x 1" Lg.

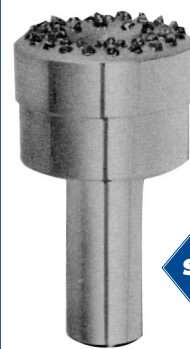

SIDLEY IMPREGNATED TOOLS

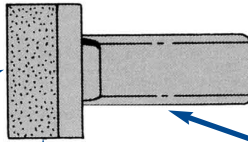

ORDERING EXAMPLE:
1A-6-A-7

1A

The number assigned from 1 to 3, pertains to the overall dimension of the diamond section. The letter pertains to the shape of the diamond section. See Shapes below.

6

Diamond Size

No. 4 for 46 grit size wheels
No. 6 for 54 to 100 grit size wheels
No. 8 for 120 and finer grit size wheels
No. 12 for special applications.

A

Shank Design
A-P

See Shank Designs at bottom of this page.

7

Shank Diameter

6 = 3/8"
7 = 7/16"
8 = 1/2"

SHANK DESIGNS

SHAPE 1A

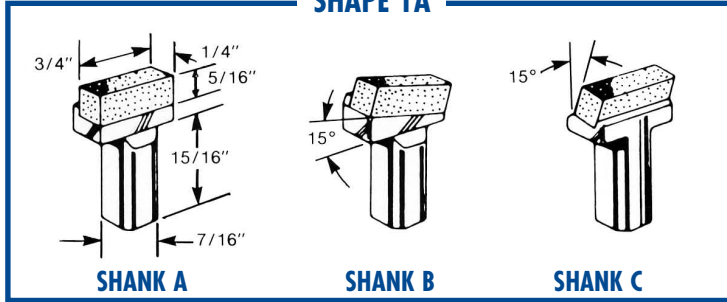

SHAPE 2A

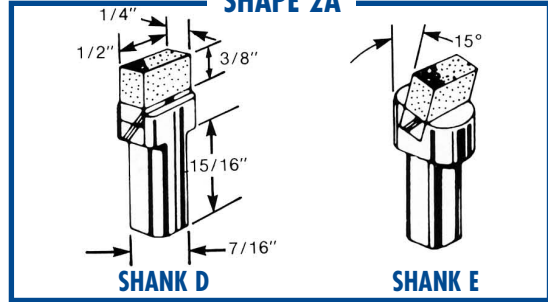

SHAPE 3A

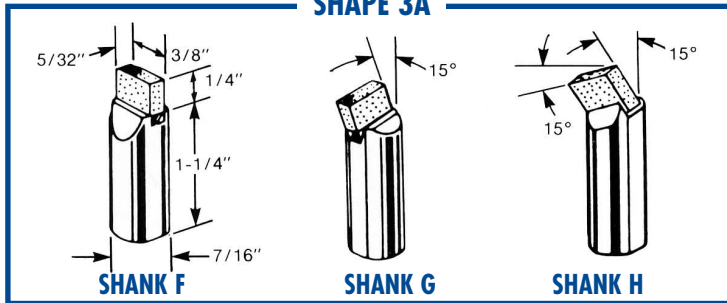

SHAPE 1B

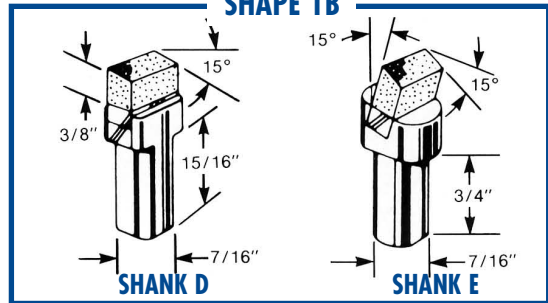

SHAPE 2B

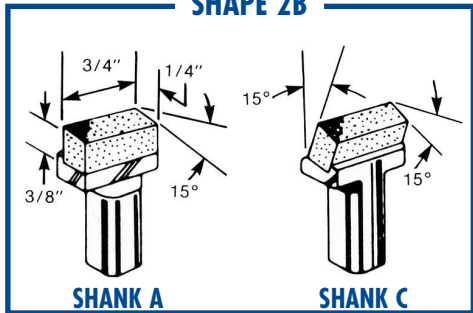

SHAPE 1E

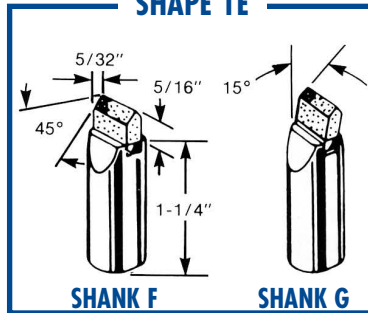

SHAPE 2E

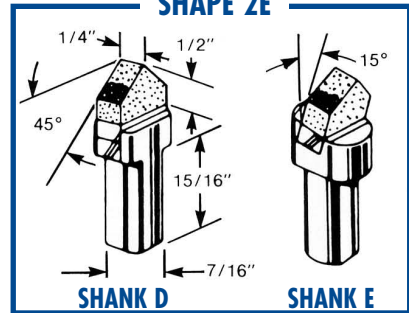

SHAPE 1R

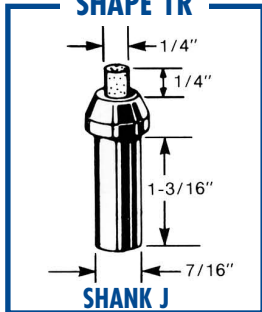

SHAPE 2R

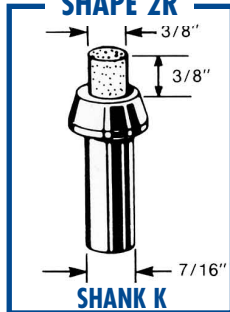

SHAPE 3R

